

# lens

Design by  
Václav Mlynář a Jakub Pollág

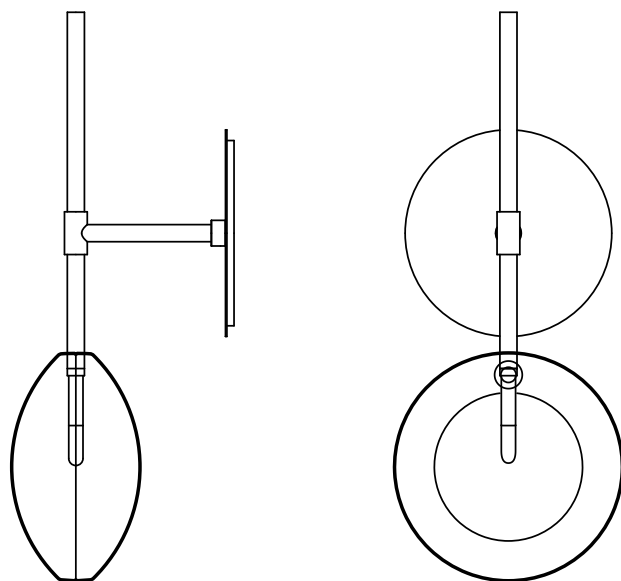

bomma

bomma.cz

TECHNICAL SHEET  
FOR WALL LIGHT FIXTURES

# LENS wall

Design by  
Václav Mlynář and Jakub Pollág

## Handmade glass attributes

The Lens Collection is made by our in-house developed, pressed glass technology. Any small bubbles, non-melts and irregularities in the glass are both proof and a characteristic feature of this unique glassmaking process.

The glass parts of Lens are hand-painted, so the intensity of color may vary slightly.

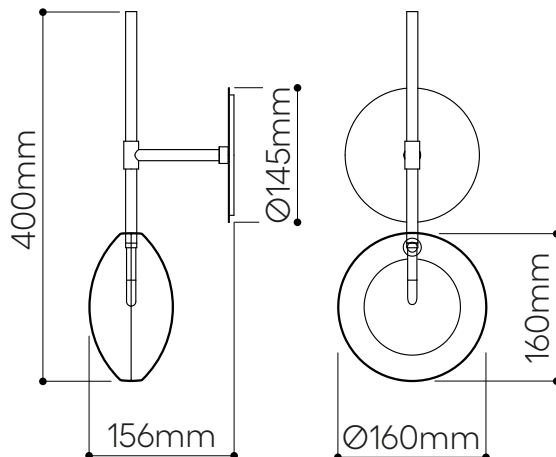

## LIGHTING DESCRIPTION

|                          |                                                                                                                          |
|--------------------------|--------------------------------------------------------------------------------------------------------------------------|
| Size                     | 160 × 156 × 400 mm<br>6,2 × 6,14 × 15,75 inch                                                                            |
| Weight                   | +/- 3,5 kg / 7,7 lb                                                                                                      |
| Glass                    | lead-free crystal in white, clear, amber, smoke, blue grey                                                               |
| Mounting                 | brushed gold (brushed brass)                                                                                             |
| Recommended junction box | EU - A.UK1-SH (72mm dia, 60mm min. depth)<br>UL/The Americas - electrical box, Octagon, 4 X 4 inch (1,4 inch min. depth) |
| Protection               | IP 20                                                                                                                    |
| Nominal voltage          | 220-240V / A.C. 50 hz (EU)<br>110-120 V / A.C. 60 Hz (USA)                                                               |
| Class                    | II. EU / I. USA                                                                                                          |

## LIGHT SOURCE

|             |                                                                  |
|-------------|------------------------------------------------------------------|
| Type        | G4, 1,2W LED, 100 lm                                             |
| Base        | G4 (EU) / G4 (USA)                                               |
| Voltage     | 12VDC, 100mA                                                     |
| Temperature | 2700 K                                                           |
| Color index | RA 90+                                                           |
| Dimming     | EU/Other versions - non-dimmable<br>UL/The Americas - TRIAC, ELV |

## TRANSFORMER

|                   |                     |
|-------------------|---------------------|
| Primary circuit   | 100-240V, 50/60 Hz, |
| Secondary circuit | 12VDC, +/-0,5A, 5W  |

## PACKAGING

|          |                                            |
|----------|--------------------------------------------|
| Material | Cardboard                                  |
| Size     | 220 × 220 × 250 mm<br>8,6 × 8,6 × 9,8 inch |

Origin: traditionally produced in the Czech Republic  
Intellectual property license holder: Bomma Czech Republic (EU)  
Represented by BMRC group s.r.o.

CERTIFICATES

